



Transportation  
Safety Board  
of Canada

Bureau de la sécurité  
des transports  
du Canada



# RAIL TRANSPORTATION SAFETY ISSUE INVESTIGATION REPORT R20H0082

**FACTORS CONTRIBUTING TO SEASONAL VARIATIONS IN TRAIN-  
MOTOR VEHICLE ACCIDENTS AT GRADE CROSSINGS**

Released 18 September 2024

Canada 

## ABOUT THIS SAFETY ISSUE INVESTIGATION REPORT

This report is the result of an investigation into a class 1 occurrence. For more information, see the Policy on Occurrence Classification at [www.tsb.gc.ca](http://www.tsb.gc.ca)

The Transportation Safety Board of Canada (TSB) investigated this occurrence for the purpose of advancing transportation safety. It is not the function of the Board to assign fault or determine civil or criminal liability.

## TERMS OF USE

### Use in legal, disciplinary or other proceedings

The *Canadian Transportation Accident Investigation and Safety Board Act* states the following:

- 7(3) No finding of the Board shall be construed as assigning fault or determining civil or criminal liability.
- 7(4) The findings of the Board are not binding on the parties to any legal, disciplinary or other proceedings.

Therefore, the TSB's investigations and the resulting reports are not created for use in the context of legal, disciplinary or other proceedings.

Notify the TSB in writing if this investigation report is being used or might be used in such proceedings.

### Non-commercial reproduction

Unless otherwise specified, you may reproduce this investigation report in whole or in part for non-commercial purposes, and in any format, without charge or further permission, provided you do the following:

- Exercise due diligence in ensuring the accuracy of the materials reproduced.
- Indicate the complete title of the materials reproduced and name the Transportation Safety Board of Canada as the author.
- Indicate that the reproduction is a copy of the version available at [URL where original document is available].

### Commercial reproduction

Unless otherwise specified, you may not reproduce this investigation report, in whole or in part, for the purposes of commercial redistribution without prior written permission from the TSB.

### Materials under the copyright of another party

Some of the content in this investigation report (notably images on which a source other than the TSB is named) is subject to the copyright of another party and is protected under the *Copyright Act* and international agreements. For information concerning copyright ownership and restrictions, please contact the TSB.

### Citation

Transportation Safety Board of Canada, *Rail Transportation Safety Issue Investigation Report R20H0082* (released 18 September 2024).

Transportation Safety Board of Canada  
200 Promenade du Portage, 4th floor  
Gatineau QC K1A 1K8  
819-994-3741; 1-800-387-3557  
[www.tsb.gc.ca](http://www.tsb.gc.ca)  
[communications@tsb.gc.ca](mailto:communications@tsb.gc.ca)

© His Majesty the King in Right of Canada, as represented by the Transportation Safety Board of Canada, 2024

Rail transportation safety investigation report R20H0082

Cat. No. TU4-45/2024E-PDF  
ISBN 978-0-660-73542-9

This report is available on the website of the Transportation Safety Board of Canada at [www.tsb.gc.ca](http://www.tsb.gc.ca)

*Le présent rapport est également disponible en français.*

## Table of contents

<b>1.0 Introduction.....</b>	<b>4</b>
<b>2.0 Investigation plan .....</b>	<b>5</b>
<b>3.0 Outcome.....</b>	<b>6</b>
<b>4.0 Preliminary observations.....</b>	<b>6</b>
<b>5.0 Future considerations .....</b>	<b>7</b>
<b>Appendices.....</b>	<b>8</b>
Appendix A – Road conditions underlie the winter increase in crossing collisions .....	8
Appendix B – The acute roadway–railway crossing angle is a key factor in collisions....	9
Appendix C – Crossing type shows a seasonal effect .....	15
Appendix D – Geographic distribution of grade crossing accidents .....	16

# RAIL TRANSPORTATION SAFETY ISSUE

## INVESTIGATION REPORT R20H0082

### FACTORS CONTRIBUTING TO SEASONAL VARIATIONS IN TRAIN–MOTOR VEHICLE ACCIDENTS AT GRADE CROSSINGS

The Transportation Safety Board of Canada (TSB) investigated this issue for the purpose of advancing transportation safety. It is not the function of the Board to assign fault or determine civil or criminal liability. **This report is not created for use in the context of legal, disciplinary or other proceedings.** See the Terms of use on page 2.

## 1.0 INTRODUCTION

As of report writing, Canada has 19 458 public active and passive grade crossings.<sup>1</sup> From 1999 to 2022, 630 people were killed and 774 were seriously injured in accidents involving collisions with trains at grade crossings.<sup>2</sup> An average of 26 fatalities due to grade crossing accidents occurred per year over that period, with 69% resulting from train–motor vehicle collisions.

TSB occurrence data for an 11-year period between 2010 and 2020<sup>3,4</sup> indicated that the number of train–motor vehicle crossing collisions varied by season, with more during winter months than during the rest of the year (Figure 1). The average number of crossing accidents per distance travelled by motor vehicles increased by approximately 61% per month in the tourist off-season winter months (January, February) compared to the tourist off-season summer-like months (May, June, September).<sup>5</sup> Analysis and comparison of Canadian TSB data<sup>6</sup> and the United States' Federal Railroad Administration (FRA) accident rate data showed that this seasonal variation was a result of winter conditions, rather than a difference in daylength as concluded by the FRA.<sup>7</sup>

<sup>1</sup> Active grade crossings are equipped with automated warning systems composed of any combination of bells, flashing lights, and gates that indicate when a train is approaching, while passive grade crossings are equipped with static signage such as crossbucks, yield or stop signs, and pavement markings.

<sup>2</sup> Specifically, 437 vehicle occupants and 193 pedestrians were killed, and 677 vehicle occupants and 97 pedestrians were seriously injured. The focus of this Safety Issue Investigation is on train–motor vehicle collisions.

<sup>3</sup> The current *Grade Crossings Regulations* entered into force in 2014.

<sup>4</sup> Dataset timeframe from S. Henderson, A. Millen, and C. M. Rudin-Brown, "Weather (not light levels) is responsible for seasonal variation in level crossing accidents," in *Proceedings of the 99th Annual Meeting of the Transportation Research Board*, Paper No. 20-04880, Washington, DC (12–16 January 2020).

<sup>5</sup> Ibid.

<sup>6</sup> S. Henderson, A. Millen, and C. M. Rudin-Brown, "Seasonal variation in North American level crossing crash rates is due to weather, not day length," in *Traffic Injury Prevention*, Volume 22, Issue 6 (2021), pp. 467–472.

<sup>7</sup> Federal Railroad Administration, "In-depth data analysis of grade crossing accidents resulting in injuries and fatalities" (2017), pp. 1–48.

Figure 1. Average number of train–motor vehicle accidents at Canadian public grade crossings, by month and type of protection, 2010 to 2020 (Source: TSB)

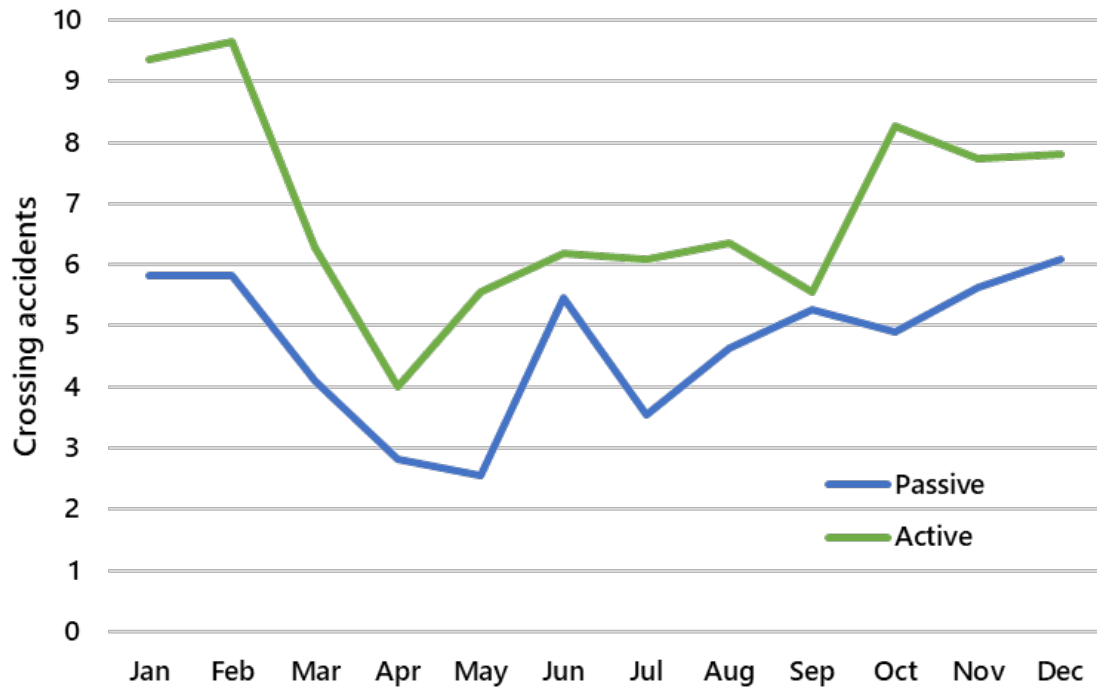

## 2.0 INVESTIGATION PLAN

To determine the detailed causes for this winter crossing accident over-representation, the TSB initiated Safety Issue Investigation R20H0082. The investigation plan was to compare recent (2018, 2019) winter (January, February) and non-winter (May, June, September) crossing accidents to identify the seasonal differences in drivers' decision making that led to the crossing collisions. A total of 94 accidents at 94 public grade crossings met the investigation criteria. Of these grade crossings, 88 were federally regulated, 4 were provincially regulated, and 2 had unknown jurisdictions.

In addition to the data held by the TSB, relevant records were provided by

- railways (i.e., Canadian National Railway Company, Canadian Pacific Railway Company, VIA Rail Canada Inc., Amtrak, CSX Corporation, Goderich-Exeter Railway Company Limited, Huron Central Railway Inc., Ontario Southland Railway Inc., and Metrolinx),
- police forces (i.e., Royal Canadian Mounted Police [RCMP], and provincial and regional police forces), and
- government agencies (i.e., Transport Canada, Business Solutions Directorate; Insurance Corporation of British Columbia [ICBC]; Ministry of Transportation of Ontario [MTO]; Safety and Policy Division, Alberta Ministry of Transportation and Economic Corridors [TRANS Collision database]; Saskatchewan Government Insurance [SGI]; and Société de l'assurance automobile du Québec [SAAQ]).

As well, structured interviews of surviving drivers were planned to acquire detailed self-reported data about the factors leading to their crossing decisions and to determine which seasonal factor(s) had the greatest effect(s) on those decisions. An additional goal of the investigation was to identify other (non-seasonal) human-factors-related causal factors for grade crossing accidents.

### 3.0 OUTCOME

Analysis of the data records provided by external agencies allowed the investigators to make some preliminary observations. However, participation by surviving drivers was low (only 15 out of 87 surviving drivers agreed to participate, with 14 completing an interview), preventing authoritative analysis of self-reported decision making (the main data to support the planned investigation analysis). As a result, the Board concluded that the lack of interview data reduced the likelihood of generating supportable findings and the decision was therefore made to suspend the investigation.

### 4.0 PRELIMINARY OBSERVATIONS

The following preliminary observations were made, and are presented in more detail in the appendices:

1. **Road conditions (Appendix A).** This was the only factor accounting for the increase in the crossing accident rate during winter. The investigation examined accident records and assigned one or more associated factors to 89 of the 94 accidents. Only *Road conditions* was almost exclusively a winter factor (2 non-winter versus 26 winter). The 14 driver interviews were consistent with that observation.
2. **Approach angle (Appendix B).** In 30 of the 94 occurrences in the dataset (32%), a train or other rolling stock approached the crossing at an angle of 80° or less relative to a vehicle's approach. (In a 2002 study,<sup>8</sup> it was observed that more than half of the 7819 grade crossing accidents in Canada between 1983 and 2001 occurred at crossings of 80° or less, or 100° or more. In the current analysis, a selection criterion of 80° or less of approach angle was chosen to ensure that the train approached from behind the driver's field of view. Angles between 81° and 99° were treated as perceptually equivalent to a right angle.) More of the 30 collisions occurred when a train approached a vehicle's passenger side (21) rather than the driver side (9), regardless of season.<sup>9</sup> Transport Canada's Rail Safety Integrated Gateway system contains data that is used by

<sup>8</sup> J. K. Caird, J. I. Creaser, C. J. Edwards, and R. E. Dewar, *A human factors analysis of highway-railway grade crossing accidents in Canada* (TP 13938E) (2002).

<sup>9</sup> The one-way Chi-square test (Chi-sq = 1.25, 1 df, p(ns)) used to obtain these numbers "sums" the differences between actual counts of the categorical variable (i.e., side of acute angle) and the expected values of 18 and 12. The probability of a Chi-square statistic this large is about 1 in 4, or p=.26 (ns). This suggests that a larger sample would show a significant result.

GradeX,<sup>10</sup> a risk assessment tool, to rank the relative risk for every public crossing in Canada, but the Rail Safety Integrated Gateway system does not always contain sufficiently accurate information to distinguish between these 2 crossing configurations.

3. **Appendix C** – seasonal effects by crossing type.
4. **Appendix D** – the dataset as a representative sample of grade crossing accidents in Canada.

## 5.0 FUTURE CONSIDERATIONS

The TSB may decide to open a future Safety Issue Investigation on this issue. Any future investigation of this nature would require a much higher driver-participation rate in order to derive authoritative conclusions about the factors involved in driver decision making.

This report concludes the Transportation Safety Board of Canada's investigation into this occurrence. The Board authorized the release of this report on 26 June 2024. It was officially released on 18 September 2024.

Visit the Transportation Safety Board of Canada's website ([www.tsb.gc.ca](http://www.tsb.gc.ca)) for information about the TSB and its products and services. You will also find the Watchlist, which identifies the key safety issues that need to be addressed to make Canada's transportation system even safer. In each case, the TSB has found that actions taken to date are inadequate, and that industry and regulators need to take additional concrete measures to eliminate the risks.

---

<sup>10</sup> GradeX "is a web application developed by the University of Waterloo, which uses an algorithm to develop a relative risk ranking of grade crossings. This algorithm can help facilitate decision-making with regard to oversight. A total of 6 risk factors are incorporated [...]". (Source: Transport Canada, *Evaluation of Rail Safety Improvement Program* (2020), at <https://tc.canada.ca/en/corporate-services/transparency/evaluation-rail-safety-improvement-program> (last accessed 07 July 2024), Section 2.1.3: Performance – targeting high risk projects.)

## APPENDICES

### Appendix A – Road conditions underlie the winter increase in crossing collisions

For 89 of the 94 occurrences in the investigation dataset, the investigation identified 14 associated factors. As Table A1 shows, most occurrences in winter and non-winter months involved *Sightline of train / crossing (sightlines)*, *Distraction*, or *Road conditions*, but only *Road conditions* was almost exclusively a winter factor (2 non-winter versus 26 winter). *Weather conditions* also showed a seasonal effect, but it was a factor in only 5 occurrences and was generally associated with *Road conditions*.

Table A1. Crossing collision factors by season

Crossing collision factor	Number of non-winter occurrences	Number of winter occurrences	Total number of occurrences
Sightline of train / crossing (sightlines)	17	21	38
Distraction	15	15	30
<b>Road conditions</b>	<b>2</b>	<b>26</b>	<b>28</b>
Fatigue	8	8	16
Road design	5	7	12
Reckless driving / Disobeying traffic signal	6	6	12
Poor (atmospheric) visibility	4	5	9
Mechanical issue	4	3	7
Confusion	3	4	7
Judgement	4	2	6
Weather conditions	1	4	5
Speed	2	2	4
Impaired driving	3	1	4
Understanding of rules and procedures	0	1	1

This shows that *Road conditions* account for the increase in the rate of crossing accidents in Canada during winter. The 14 driver interviews (10 winter, 4 non-winter) support that observation.



## Appendix B – The acute roadway–railway crossing angle is a key factor in collisions

Oblique angle crossings are known to be higher risk for road users, and the Safety Issue Investigation observations are consistent with the literature.<sup>11,12,13</sup> The collision angle in 30 of the 94 occurrences in the Safety Issue Investigation dataset (32%) was 80° or less. That is, a train or other rolling stock approached the crossing at 80° or less relative to the vehicle's approach. That selection criterion was chosen to ensure that the train approached from behind the driver's field of view, and is consistent with an observation from a 2002 study that over half of grade crossing accidents in Canada from 1983 to 2001 occurred at grade crossings skewed by 10° or more from the perpendicular.<sup>14</sup> Angles between 81° and 99° were treated as approximate right angles (i.e., perceptually equivalent to a right angle). More of the 30 collisions involved a train approaching from the passenger side (21) than from the driver side (9),<sup>15</sup> regardless of the season. However, some of this difference is because 60% of oblique angle crossings skewed by 10° or more have an acute angle on the passenger side.<sup>16</sup> Therefore, with the current data it was not possible to draw any conclusions about relative risk by side (driver or passenger) of acute angle. Figure B1 shows a breakout of the 21 passenger-side (blue) and 9 driver-side (orange) collisions by crossing type, light, and season.

---

<sup>11</sup> U.S. Department of Transportation, Federal Railroad Administration, report no. DOT/FRA/ORD-17/04, "In-depth data analysis of grade crossing accidents resulting in injuries and fatalities" (11 May 2017), p. 41.

<sup>12</sup> J. K. Caird, J. I. Creaser, C. J. Edwards, et al., "Human factors analysis of highway-railway grade crossing accidents in Canada" (TP-13938E) (2002), pp. 8, 52–53, and 68.

<sup>13</sup> L. Åberg, "Driver behavior at flashing-light, rail-highway crossings," in *Accident Analysis and Prevention* (1988), Volume 20, Issue 1, pp. 59–65.

<sup>14</sup> J. K. Caird, J. I. Creaser, C. J. Edwards, et al., "Human Factors Analysis of Highway-Railway Grade Crossing Accidents in Canada" (TP-13938E) (2002), pp. 8, 52–53, and 68.

<sup>15</sup> (Chi-sq = 1.25, 1 df, p(ns)). See Footnote 9 for an explanation of this statistic.

<sup>16</sup> Visual inspection of Google Maps images of 400 randomly selected grade crossings skewed by 10° or more determined that 60% had the acute angle on the passenger side.

Figure B1. Graph showing the number of collisions at passive and active crossings in which the train approached the crossing from behind the driver at an angle of  $\leq 80^\circ$ , by time of day, season, and side of approach (Source: TSB)

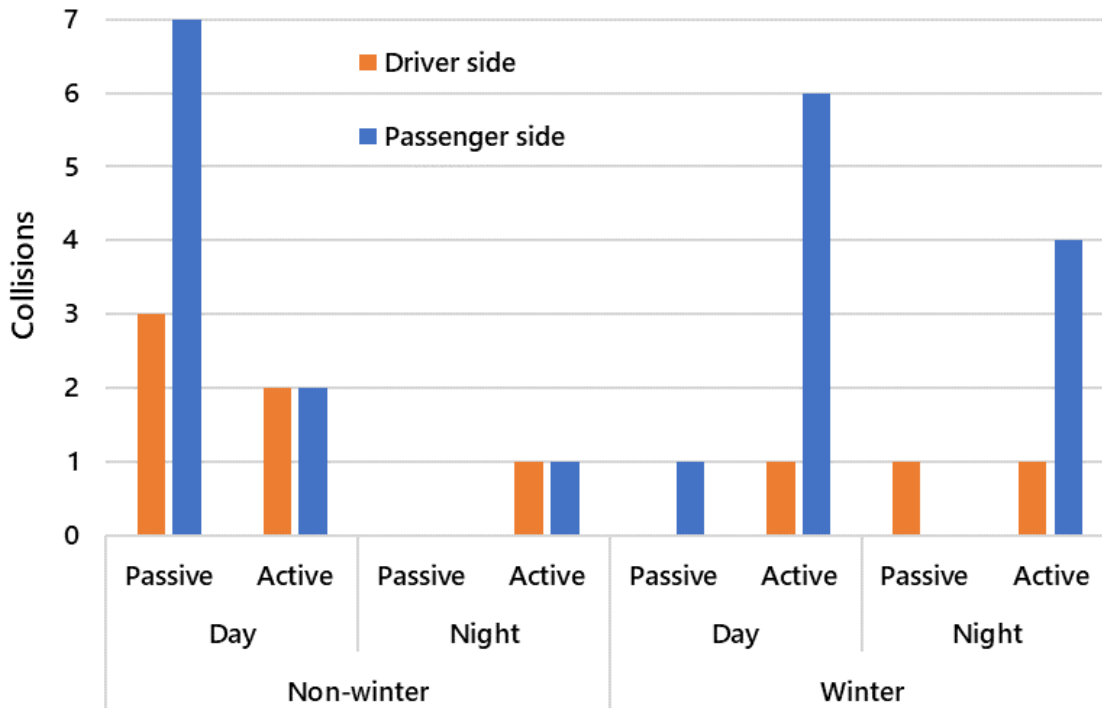

The left diagram in Figure B2 shows the approximate crossing angle configuration of the 9 driver-side acute angle collisions (the train approached from the driver’s left), and the right crossing shows the approximate crossing angle configuration of the 21 passenger-side acute angle collisions (train approaching from the driver’s right). Therefore, oblique crossings where a train may approach at an acute angle from the passenger side (Figure B2, right diagram) appear riskier than oblique crossings where a train may approach at an acute angle from the driver side (Figure B2, left diagram). A sample size larger than this sample of 30 acute angle approaches would be necessary to determine if the difference is statistically significant. That larger sample is not available from TSB’s Railway Occurrence Database System because the side of vehicle impact for most grade crossing accidents is not recorded there.

Figure B2. Two diagrams showing oblique crossings with crossing angles greater than  $90^\circ$  and at  $90^\circ$  or less respectively (Source: Transport Canada, Grade Crossings – Handbook [2016], Figure 8-3b, at <https://tc.canada.ca/en/rail-transportation/grade-crossings/grade-crossings-handbook> [last accessed 22 August 2024])

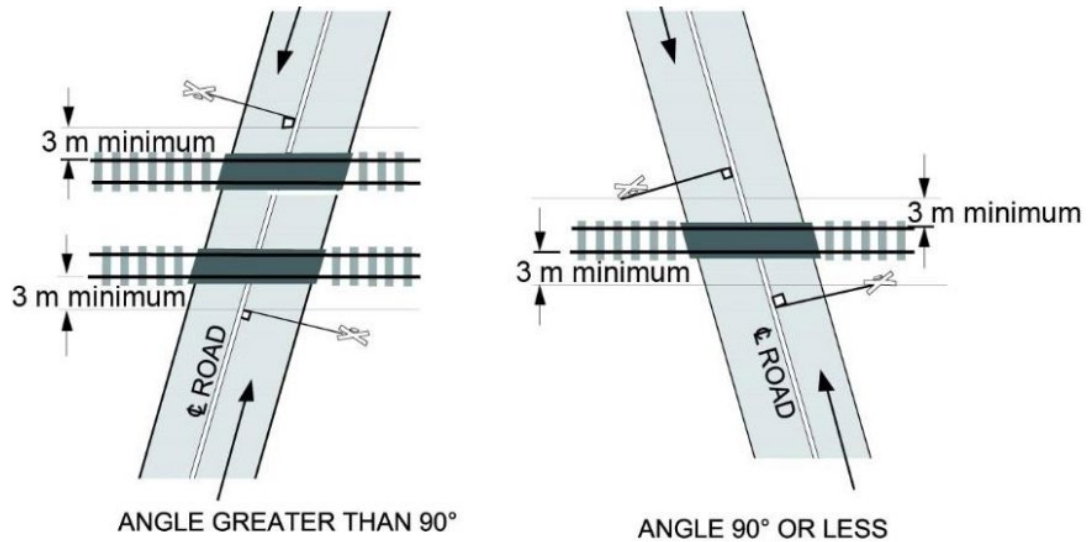
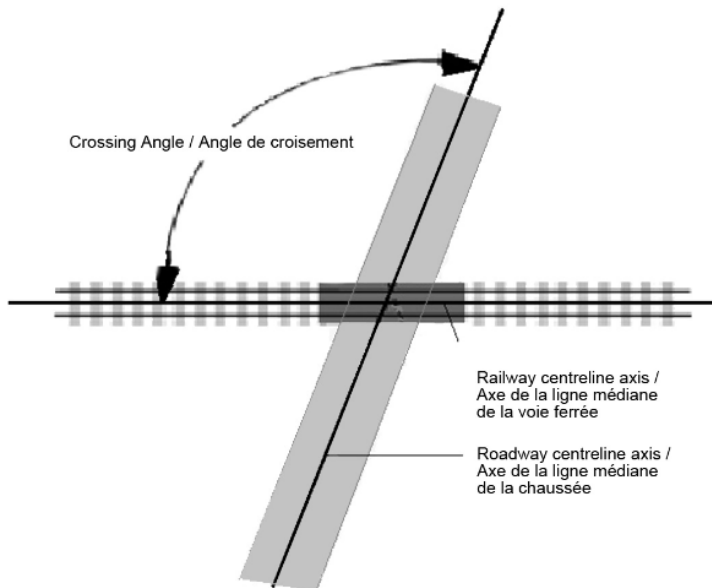

Figure B3, which illustrates crossing angle measurement, demonstrates that the angles indicated in Figure B2 show not only where to place signage, but also defines where to measure the crossing angle. “Crossing angle” refers to the angle of the track relative to the road, measured on the side of the road where the crossing signals or signage are found. Oblique angle crossings with angles qualitatively similar to the left crossing in Figure B2 are referred to as obtuse angle crossings (i.e., crossing angle greater than  $90^\circ$ ), and oblique crossings with angles qualitatively similar to the right crossing in Figure B2 are referred to as acute angle crossings (i.e., crossing angle less than  $90^\circ$ ).

Figure B3. Diagram showing the measurement of a grade crossing angle (Source: Transport Canada, Grade Crossings – Handbook [2016], Figure G-2, at <https://tc.canada.ca/en/rail-transportation/grade-crossings/grade-crossings-handbook> [last accessed 22 August 2024])



Transport Canada's Rail Safety Integrated Gateway (RSIG) system contains data that is used by GradeX to rank the relative risk for every public crossing in Canada. The RSIG system does not always contain sufficiently accurate information to distinguish between those 2 crossing configurations in order to assess crossing risk by side of acute angle. The RSIG system contained crossing angle data for 18 451 of the 19 458 public crossings in use in Canada as of 2019. Those data indicate that 11 086 grade crossings (57%) were less than 90° while 1360 (7%) were greater than 90°,<sup>17</sup> as shown in Figure B4. In fact, the actual ratio of acute angle to obtuse angle grade crossings was 3:2 for 400 skewed public grade crossings randomly selected from RSIG, which suggests that an estimated 3200 obtuse angle grade crossings may currently be misidentified<sup>18</sup> as acute angle grade crossings in RSIG.

<sup>17</sup> In addition, 6005 grade crossings (31%) were at 90° and 1007 (5%) had no available angle information.

<sup>18</sup> Between 2019 and 2023, 411 crossings in RSIG were changed from acute angle to obtuse angle.

Figure B4. Graph showing the number of active and passive public crossings in urban and rural areas by crossing angle (Source of diagram: TSB; source of data: Transport Canada RSIG system [2020])

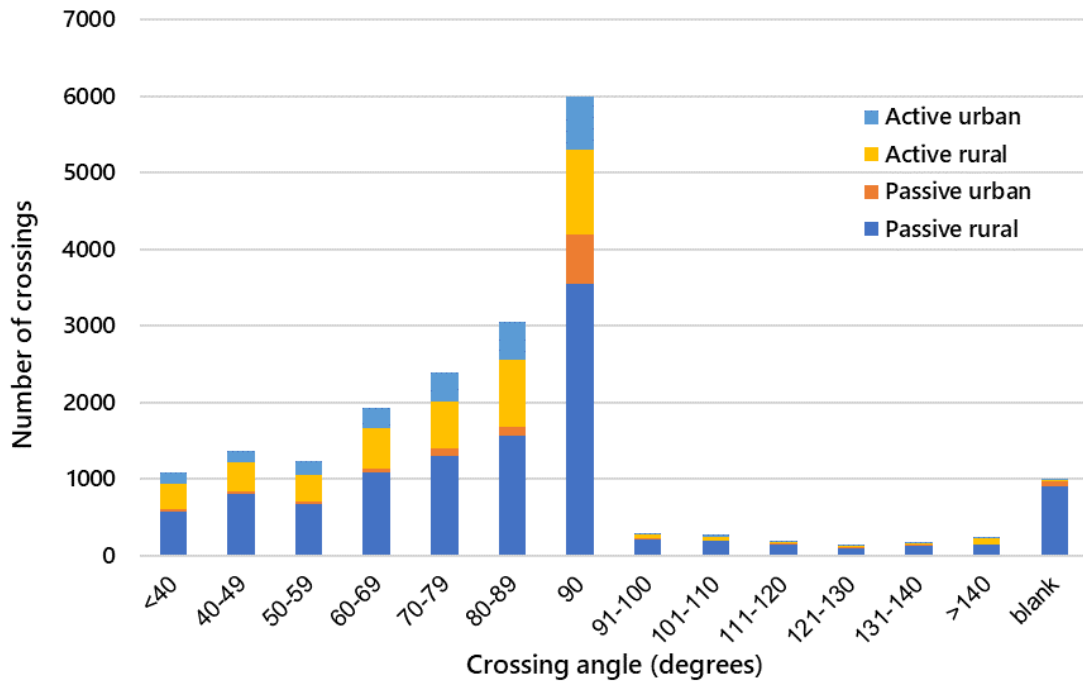

This misidentification may occur because TC's *Grade Crossings – Handbook*<sup>19</sup> does not specify in the text where and how the angle should be measured, and as a result the smallest angle is measured and recorded. (Over 90% of the non-perpendicular crossings involved a measurement from the road to the nearest track.) Although Figure B3 (from the *Grade Crossings – Handbook*) graphically illustrates where to measure a grade crossing angle, the text does not completely specify which tangent should define each side of the angle:

**6.1.5** A grade crossing angle, measured from the tangent of the centreline of the road approach at the crossing surface to the tangent of the centreline of the line of railway [...]<sup>20</sup>

The result of the incomplete specification of a procedure for measuring crossing angle is that the RSIG crossing database cannot be used to quantify angle-related differences in risk, or to accurately rank crossings by risk and apply effective countermeasures according to that ranking. To illustrate, the right crossing shown in Figure B2 appears riskier than the left crossing, yet the 2 will likely have the same crossing angle recorded in the RSIG.

Distinct crossing angles for acute and obtuse angle crossings could be achieved by specifying that crossing signals or signs must lie between the tangent limits of the measured

<sup>19</sup> Transport Canada, *Grade Crossings – Handbook* (2016), pp. 24–25, at <https://tc.canada.ca/en/rail-transportation/grade-crossings/grade-crossings-handbook/part-b-design-standards#article-6> (last accessed 22 August 2024).

<sup>20</sup> Ibid.

crossing angle. If the complementary (other) angle is most conveniently measured, then the crossing angle would be recorded as  $180^\circ$  minus the measured angle.

### Appendix C – Crossing type shows a seasonal effect

In the dataset of 94 grade crossing accidents, active crossings showed a seasonal (i.e., winter) increase in accidents, particularly at urban gated crossings and at rural “flashing lights and bells” (FLB) crossings, while there was a winter-time drop at passive crossings for all locations (Figure C1).

Figure C1. Graph showing the number of collisions by type of crossing (gated, with flashing lights and bells, and passive grade), season (winter and non-winter), and location (urban, rural, and industrial) (Source: TSB)

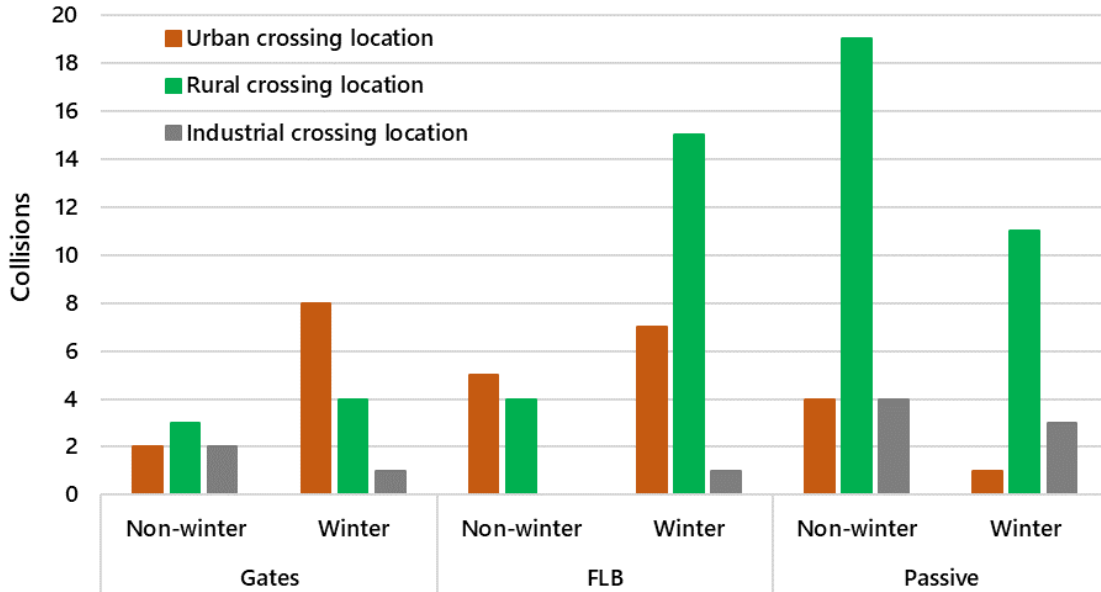

## Appendix D – Geographic distribution of grade crossing accidents

The dataset (Table D1, row 1) shows a similar geographic distribution as all reported crossing accidents over a 9-year period (Table D1, row 2), a similar geographic distribution as all fatal and serious injury grade crossing accidents in 2018 and 2019 (Table D2), and a similar geographic distribution as public grade crossings overall (Table D3). Therefore, the dataset is a geographically representative sample of the population of public grade crossing accidents in Canada.<sup>21</sup>

**Table D1. Number and percentage of crossing accidents in Safety Issue Investigation periods and baseline years, by province or territory**

Time periods	NL	NS	NB	QC	ON	MB	SK	AB	BC	NT	Total
Safety Issue Investigation accidents (Jan, Feb, May, Jun, Sep; 2018 and 2019)	0 (0%)	0 (0%)	1 (1%)	8 (9%)	24 (26%)	16 (17%)	15 (16%)	23 (24%)	7 (7%)	0 (0%)	94
2011 to 2017, 2020, 2021	2 (0%)	11 (1%)	32 (2%)	200 (14%)	292 (20%)	155 (11%)	231 (16%)	335 (23%)	178 (12%)	2 (0%)	1438

**Table D2. Number of accidents with fatal or serious injuries at public passive and active grade crossings, by province or territory, 2018–2019**

Type of grade crossing	NL	NS	NB	QC	ON	MB	SK	AB	BC	NT	Total
Passive	0	0	0	2	5	5	6	3	2	0	23
Active	0	0	0	6	22	5	11	10	12	0	66
Total	0	0	0	8	27	10	17	13	14	0	89

**Table D3. Public passive and active grade crossings,\* by province or territory, 2019**

Type of grade crossing	NL	NS	NB	QC	ON	MB	SK	AB	BC	NT	Total
Passive	2	149	264	1110	2404	1586	4199	2061	784	8	12 567
Active	5	184	260	1388	2501	523	614	815	599	2	6891
Total	7	333	524	2498	4905	2109	4813	2876	1383	10	19 458

\* Source: Transport Canada RSIG system crossing data (2019)

<sup>21</sup> Prince Edward Island, Nunavut and Yukon are not shown as they contain no public grade crossings.